

UV-LED Overview Part I — Operation and Measurement

By Jennifer Heathcote

Ultraviolet-curing systems that incorporate light-emitting diodes (UV-LEDs) and applications utilizing UV-LED technology have been highlighted at conferences, profiled at tradeshows and incorporated into both prototype and production systems (albeit to varying degrees of success) since the turn of the 21st century. It's hard to believe that in some markets, particularly UV digital ink jet, we have been studying, trialing, promoting and integrating UV-LED systems for nearly a decade. With the most recent advancements in the technology, we are now achieving comparable

This new, pro-LED climate is great for generating activity in many diverse markets, but the challenge has now become one in which the majority of those who are newly interested in UV-LEDs have insufficient understanding of the underlying technology.

production speeds and throughcures to those found in setups using traditional forms of electrode and microwave UV curing. While UV-LEDs are still not the right fit for many applications, the momentum of technological advancement and implementation continues to increase at an astonishing and exciting rate, thus making many more applications a plausible reality.

Most UV-LED articles and professional society presentations delivered during the previous decade of development have predominantly revolved around two distinct topics. The first promotes the technology by touting the limitless number of environmental,

process and integration benefits that UV-LEDs have over conventional UV curing systems. The second topic cautions against practical limitations, lack of established installations, limited availability of inks and coatings, and uncertainties regarding the UV-LED development timeline. These latter communications have been more of an effort not to oversell the capabilities of the technology and to counter the potentially disruptive nature of LEDs toward electrode and microwave UV-curing systems. Well, I think it's finally safe to say, "Message received." Most users involved in UV curing and related technologies now readily accept the fact that UV-LEDs are the present and the future, while at the same time they realistically understand that UV-LEDs may not yet fit all their curing needs today.

This new, pro-LED climate is great for generating activity in many diverse markets, but the challenge has now become one in which the majority of those who are newly interested in UV-LEDs have insufficient understanding of the underlying technology. Those of us promoting UV-LEDs have successfully sold potential users on the concept but then left many of them unsure as to how and when to actually implement the technology into their processes. They don't always know what questions to ask or fully grasp the information they are provided. Through no fault of their own, many users simply don't have a sufficient foundation to compare available UV-LED systems or understand how to correlate product and performance

FIGURE 1

P-n junction

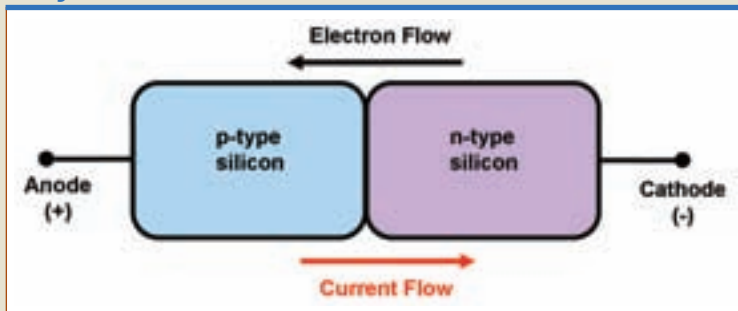

information against traditional curing lines. This means that suppliers must spend a good portion of our time educating and refining expectations, while at the same time continuing to learn alongside our ink, coating and dispensing partners.

In an effort to consolidate some key principles and technical information regarding the science and engineering behind UV-LEDs, I will attempt to present an elementary foundation through a series of three articles. The first article is meant to cover LED operation and measurement and will include information on (1) the p-n junction, which is the basic building block of the LED; (2) the LED p-n junction; (3) characteristics of UV output from LEDs as compared to conventional UV bulbs; and (4) the

challenges associated with measuring UV output from LED sources. The two subsequent articles will focus on integration of UV-LED chips into actual curing systems, as well as the history of LED development and current diode manufacturing methods. Each article will conclude with a brief summary consisting of a series of questions intended to guide the reader as he/she compares UV-LEDs and benchmarks them against conventional UV systems.

The P-N Junction

In electrical circuits, conventional current flows from a positive terminal to a negative terminal. In order for current to flow in this direction, electrons must simultaneously flow through the same circuit in the reverse direction (i.e., from a negative to

a positive terminal). One does not happen without the other. A diode is a common electrical device that is added to a circuit as a means of restricting the flow of electricity. It can generically be thought of as a switch or a valve. A key property of a diode is that it conducts electricity in only one direction. A p-n junction (positive-negative junction) is a specially engineered diode that is made of many layers of semi-conductive materials where each layer is less than half a micron thick. The concept is commonly illustrated with the diagram in Figure 1.

A p-n junction is engineered from a single piece of semi-conductive crystal. Impurities are impregnated or doped into the semiconductor and the two sides (p and n) undergo a manufacturing process that results in the p-side of the junction becoming a positively charged electrode while the n-side becomes a negatively charged electrode. The two sides of the diode are referred to as the anode (+) and the cathode (-) respectively. Current is able to flow from the p-side of the diode to the n-side, but it cannot flow in the reverse direction. Electrons, however, only flow from the n-side to the p-side.

The junction boundary where the p-side and the n-side meet is called the depletion zone. While both the p-side and the n-side are relatively conductive, the depletion zone is not. This means that without altering the characteristics of the depletion zone, current and electrons will not flow through the p-n junction at all. If the depletion zone is minimized in both size and effectiveness, electrons will be able to penetrate the boundary and move from n to p. The result is that electricity is able to flow from the positive terminal to the negative terminal of a low-voltage supply when the supply is connected directly to the anode and cathode of the junction.

In Figure 2, a voltage supply is added to the diagram. When the anode

FIGURE 2

Forward bias

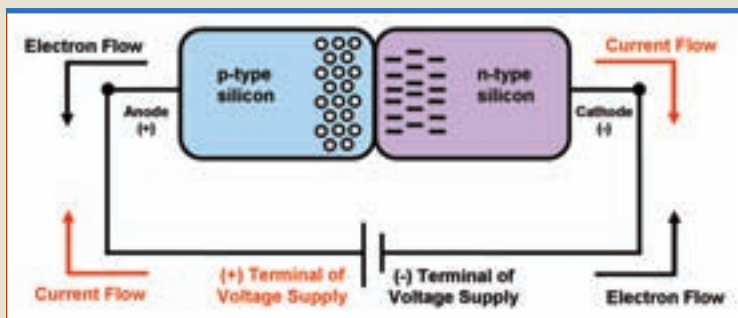
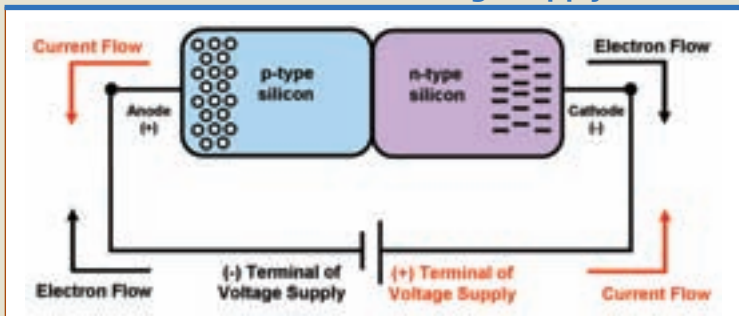

FIGURE 3

Reverse bias with sufficient voltage supply



flow from the positive terminal of the voltage supply through the n-side, across the depletion zone and through the p-side to the negative terminal of the supply. Zener or avalanche diodes are based on this scenario.

The LED P-N Junction

A light-emitting diode is a p-n junction which, depending on the semiconductor structure, could theoretically be designed to emit monochromatic wavelengths throughout the entire electromagnetic spectrum. This is known as electroluminescence and it occurs at room temperature—as opposed to the more familiar incandescence which is only produced when materials are heated to temperatures above 750°C (heat glow). A physical example of an actual LED p-n junction is illustrated in Figure 4. Both the anode (+) and cathode (-) connections—as well as the semiconductor, wire bond and protective outer case or lens—are shown in the sketch. Today, LEDs that emit infrared (870-980 nm), visible (390-780 nm), and some ultraviolet (365-405 nm), as shown in Figures 5 and 6, are used in a wide variety of applications.

FIGURE 4

LED p-n junction (forward bias)

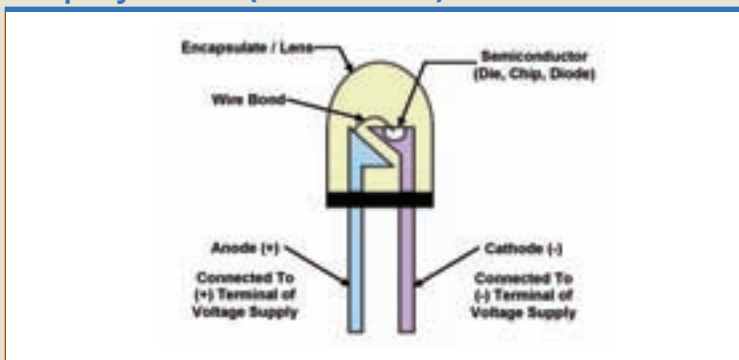

is connected to the positive terminal of the voltage supply and the cathode is connected to the negative terminal, a forward bias is created. Imagine that the p-side of the junction is composed of tiny, positively charged holes while the n-side contains a lot of negatively charged electrons. The effect of a forward bias voltage is that the positive holes in the p-region and the negative electrons in the n-region are pushed from opposite directions toward the depletion zone. This significantly reduces the width of the depletion zone, causing the electrons on the n-side to respond to the attractive forces of the holes on the p-side. When a sufficient voltage is used, the electrons penetrate through the barrier

to fill the holes on the p-side. This is called recombination.

Switching the connections on the voltage supply creates a reverse bias situation. In this case, the negative terminal of a voltage supply is connected to the anode and the positive terminal is connected to cathode. The resulting effect is that the positive holes in the p-region and the negative electrons in the n-region move away from the depletion zone as they are attracted to the opposing charge on the voltage supply. This increases the width of the depletion zone and inhibits the flow of electricity. In certain cases where a high enough voltage is applied, the p-n junction can break down causing current to

All of the concepts presented for the simple p-n junction apply to the LED. When a voltage source is connected to the LED with a forward bias, current flows from the p-side to the n-side (anode to cathode). As the electrons cross the depletion zone and fill a hole, they drop into a state of lower energy. The excess energy is released in the form of a photon that can transport electromagnetic radiation of all wavelengths, including infrared (IR), visible and UV light. The selection of semiconductor and doping materials determines the exact wavelengths emitted from the diode when the photon is released. Different dopants possess varying band gap energies that, at an atomic level and

FIGURE 5

Electromagnetic spectrum

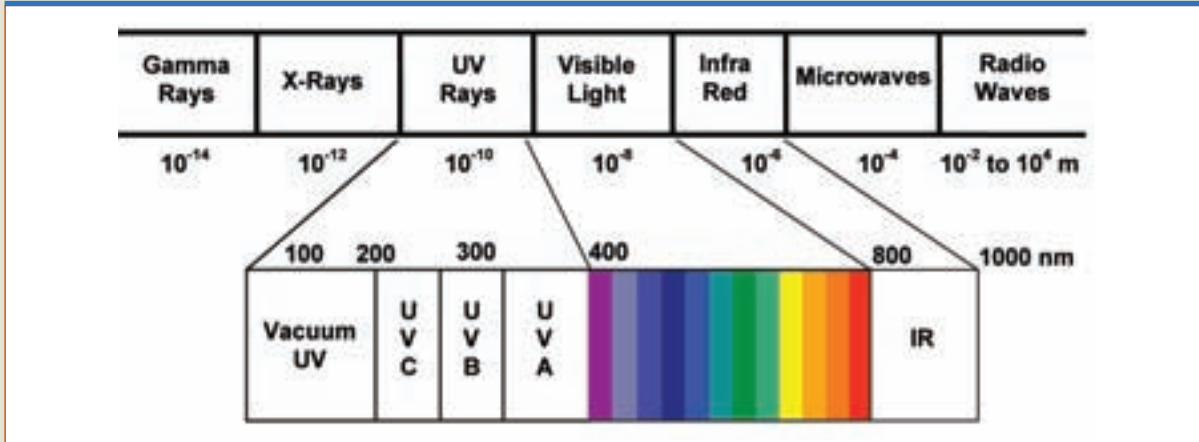
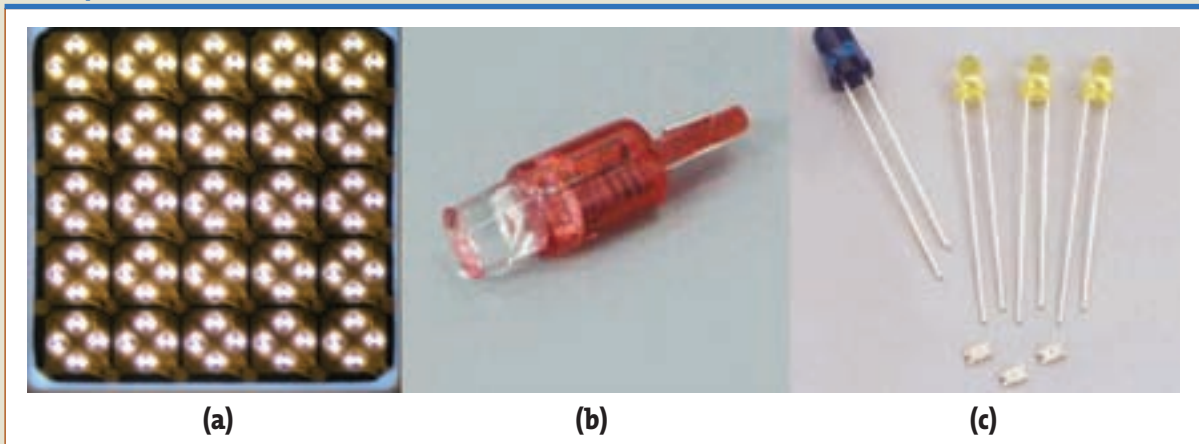

FIGURE 6

Examples of (a) UV (b) visible and (c) IR-LEDs



not something covered in this article, determine the specific wavelength that is emitted from an LED.

While the LED was first observed in 1907, it was only in the last 50 years that LEDs emitting sustainable and useful wavelength(s) have truly evolved. Optimal combinations of semiconductor materials and dopants were intentionally and unintentionally identified through experimentation and trial-and-error. The primary challenge has always been that these

experiments could not be easily controlled, and it was difficult to understand exactly how the emission occurred or what was causing it. Early successes were achieved with longer wavelength visible light and infrared. It wasn't until 1992 that a UV-LED with an efficiency of around 1% was produced in a lab environment in Japan, and it wasn't until about 2002 that UV-LED curing systems with efficiencies in the single digits began to enter the market. Tables 1 and 2

provide common examples of inorganic semiconductor materials as well as the corresponding wavelength regions.

It is possible to follow the evolution of LEDs over the last 50 years by considering the introduction of standard household goods into daily life. Red LEDs were first used as status and function indicators on mainframe computers, circuit boards and multiline telephones in the mid 1960s. In the '70s and '80s, TV remotes and garage door openers (which both employ

TABLE 1

Core semiconductor materials¹

Materials	Wavelength
Silicon	190-1,100
Germanium	400-1,700
Indium gallium arsenide	800-2,600
Lead sulfide	1,000-3,500

IR-LEDs) were introduced, as well as red indicator LEDs on appliances and electronics. Green LEDs were used to illuminate the dial pads on early push-button telephones, and LEDs used for alphanumeric displays on digital calculators, watches and signs became common.

By the beginning of the 1980s, liquid crystal displays (LCDs) replaced LEDs on watches and calculators; however, LEDs continued to be used as back lighting. In the late '90s, as engineers gained greater understanding and control of the manufacturing materials, more visible colors entered the market and were subsequently used in all types of electronics, as well as for both decoration and function in automobiles, airplanes and buildings. Extremely bright LED flashlights came onto the market around the turn of the century, and IR-LEDs were introduced for use in security cameras. They are now commonly used for video and audio controls as well as for local area communication networks. Starting in 2004, arrays of red, white and green LEDs were designed for use as automotive headlights and taillights as well as traffic and pedestrian crossing signals.

In the last 10 years, the technology underlying white light LEDs has emerged and the overall cost of visible LEDs has been driven down to the point that they are readily available at any brick-and-mortar or online electronics store. Red indicator LEDs can now be purchased for pennies as opposed to the several hundred dollar-per-unit price of the '60s. Today's blue LEDs, which are a more recent development, still cost several dollars in comparison. Larger urban areas have recently become populated with electronic LED billboards that can quickly change display as traffic streams past. Despite all these advances, further expansion of LED

TABLE 2

Engineered semiconductor combinations¹

Materials	Wavelength
Aluminum gallium arsenide (AlGaAs)	Red and Infrared
Aluminum gallium phosphide (AlGaP)	Green
Aluminum gallium indium phosphide (AlGaInP)	Bright orange red, orange, yellow, green
Aluminum gallium indium nitride (AlGaInN)	Ultraviolet - down to 210 nm
Aluminum gallium nitrate (AlGaN)	Near to far ultraviolet, violet
Aluminum nitrate (AlN)	Near to far ultraviolet
Boron Nitride	Ultraviolet
Diamond (C)	Ultraviolet
Gallium arsenide phosphide (GaAsP)	Red, orange and red, orange, yellow
Gallium Arsenide (GaAs)	Infrared
Gallium phosphide (GaP)	Red, orange, yellow, green
Gallium nitrate (GaN)	Green, emerald green
Gallium nitrate (GaN) with AlGaN quantum barrier	Blue, white
Indium gallium nitrate (InGaN)	Bluish green, blue, near ultraviolet
Sapphire (Al ₂ O ₃) as substrate	Blue
Silicon (Si) as substrate	Blue (under development)
Silicon carbide (SiC)	Blue
Zinc selenide (ZnSe)	Blue

FIGURE 7

Spectral output of LED systems compared to traditional UV system

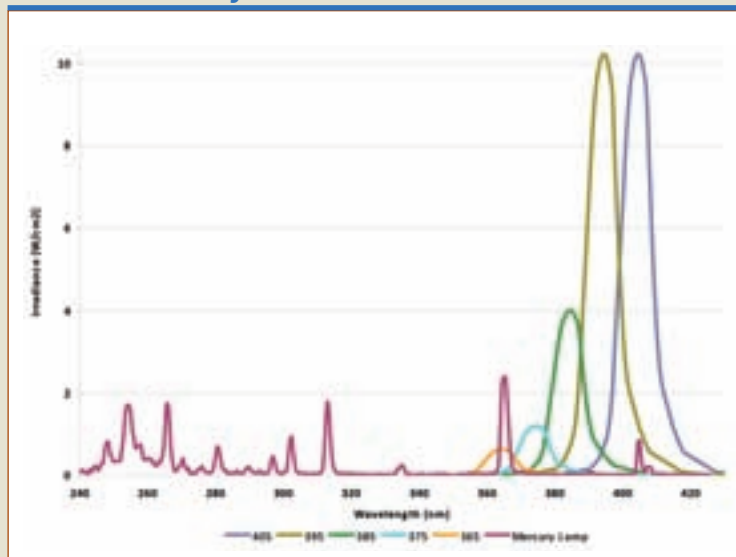

technology across both the visible and UV spectrum still presents many challenges and will continue to do so into the foreseeable future.

The specific design of an individual UV-LED chip or diode depends on the desired wavelength, peak UV irradiance and capabilities of the LED chip manufacturer. While the physical size of the chip can vary by design or supplier, the device tends to be around 1 mm square. The individual LED diodes are then combined and packaged in various ways to produce larger arrays targeted to specific applications. The actual packaging and integration of these chips into larger diode assemblies or a full UV-curing system will be covered in article two. For the purposes of this article, use of the words chip, diode or die refers to the individual LED semiconductor, while LED array implies the full curing assembly, historically known as the lamp head or irradiator. Any given LED array will incorporate tens, hundreds or even thousands of LED chips in its overall design.

UV-LED Output as Compared to Arc and Microwave

While LED, mercury arc and microwave systems all emit UV energy, UV-LEDs have unique characteristics that make the spectral output very different from that of more conventional systems. First of all, UV-LEDs emit a relatively monochromatic band of UV that is centered at a specified peak wavelength; whereas, arc and microwave systems are broadband emitters with a range of output between 200 and 445 nm. Common wavelength peaks for UV-LED systems are 365, 375, 385, 395 and 405 nm. Figure 7 illustrates this difference. The magenta spectral output in the chart is from one conventional UV-arc system; whereas, the five monochromatic peaks toward the right half of the chart were emitted from five separate LED chips with outputs centered at their respective peak wavelength.

Over the past 60 years, UV chemistry has been formulated to react with

broadband spectrums utilizing the shorter wavelengths for surface cure and the longer wavelengths for penetration and adhesion. Much of that chemistry relies heavily on photoinitiators tuned to 365 nm. As a result, not all previously formulated broadband UV ink chemistry will work with monochromatic LEDs. In many cases, the chemistry must be reformulated to react and accomplish the same or similar cure results within the more restrictive but also incredibly more intense band of LED output. While this no doubt presents challenges, it also yields the positive aspect of eliminating the infrared and UVC components. As a result, when compared to conventional curing, there is less heat transfer to the substrate (no IR) and no harmful UVC rays or resulting ozone to address. The UV from current LEDs is all UVA with a slight visible component in the violet wavelength range.

Secondly, what is often surprising to those new to UV-LED technology is that longer wavelength UV-LEDs (385, 395 and 405 nm) actually emit more UV irradiance at their peak wavelength than conventional UV bulbs. This is also illustrated in Figure 7 which shows peak irradiance at 395 nm and 405 nm of 10 W/cm² for the LED system and 2 W/cm² at 365 nm for a conventional UV system. The LED chips used to create the chart emit up to five times the peak irradiance of microwave and mercury arc systems; however, it is concentrated in a very narrow bandwidth. When users first view an LED system in operation, they often comment that the light appears “brighter” or “more purple” than conventional UV systems. This is due to the greater irradiance of UV-LEDs and the fact that for 395 and 405 nm LEDs, a portion of the UV output curve is actually in the visible portion of the spectrum.

Thirdly, the output of a UV-LED is based on the amount of current flowing through the chip. This will be covered in more detail in article two as well as LED and total power consumption. For now, simply note that the irradiance of an LED chip increases or decreases as the forward current through the chip changes. This is different than arc and microwave systems which require more energy from physical ballasts and magnetrons to produce additional UV. While there are many advantages to this that will be covered in article two, one primary advantage that anyone who has experience handling UV systems can appreciate is that the power supplies for LED systems are significantly smaller and lighter than those needed for conventional UV systems.

Finally, UV-LED chips are currently less efficient than conventional UV systems as well as visible and IR-LEDs. This is often a surprise to most people as visible LEDs have become increasingly common in everyday society and their high energy efficiencies have been strongly promoted in recent news features. Seasonal holiday decorations now incorporate visible LEDs that require little if any cooling, claim to last indefinitely, are 80-90% more efficient than normal lights and are relatively inexpensive. If only this were the case for UV-LEDs. Unfortunately, present technical limitations render UV-LEDs around 10 to 20% efficient for longer wavelengths (395 and 405 nm) and less than 10% for shorter wavelengths (365 nm). This is because UV-LED dies have only recently evolved out of IR and visible LED developments and have not yet been optimized for the UV region.

As more and better combinations of semiconductors and dopants have been discovered and engineered, a wider, more intense and increasingly efficient range of wavelengths and

outputs could be produced. The longer wavelength UV-LEDs (395 and 405 nm) more closely resemble LEDs in the visible spectrum. Since the visible technology is more established, it is easier for chip manufacturers to produce more powerful and more efficient LEDs at wavelengths closer to the visible spectrum as compared to shorter wavelength UV-LEDs (365 and 375 nm). This is exemplified by the decreasing UV peaks shown in Figure 7 as one moves left along the chart. With continued improvements in the science and manufacturing process, UV-LEDs will increase in both output and electrical efficiency. For now, it is important to simply realize that with today's technology it may take more total consumed energy to produce the necessary UV output for your specific application than would be the case with conventional curing.

The fact that today's UV-LEDs are inefficient is the only reason that liquid chillers must be used for cooling the higher output arrays as opposed to using air cooling. Less than 20% of the electrical energy supplied to the LED system is actually converted into UV. As a result, the remaining energy is wasted as heat. The amount of heat energy is so significant that the only way to effectively remove it from the system is by circulating a liquid coolant around a heat sink attached to the chips. In general, systems that are rated below 4 W/cm² can be effectively cooled with air; however, less than 4 W/cm² is not normally a sufficient irradiance for most curing applications. All arrays rated at 4 W/cm² or higher must presently be cooled with a liquid chiller.

As the individual chip technology improves, the higher output systems will eventually be cooled with air. It is even possible that one day little to no additional cooling will be needed. Unfortunately, it is difficult to know if that reality is five or 50 years into

the future. For now, simply know that UV-LEDs have the promise of being incredibly energy efficient and, in certain applications in which the LED array and the chemistry are precisely matched, the application can be considered more efficient than conventional UV curing. The energy savings for most current LED applications, however, is negligible when compared to conventional curing applications due to the need for the chiller. Don't just assume that UV-LEDs translate into direct energy savings. Sometimes it is the case and sometimes it isn't. One must run the numbers to be sure.

Measuring UV-LED Output

Before discussing how to measure UV output from LEDs, let's review the definitions of irradiance (intensity) and energy density (dose). In the RadTech UV Glossary and in many articles written by Jim Raymont of EIT that have been published in previous issues of the *RadTech Report*, irradiance and energy density are defined as follows.

Irradiance is the radiant power arriving at a surface-per-unit area. With UV curing, the surface is most often the substrate and a square centimeter is the unit area. Irradiance is expressed in units of watts or milliwatts per square centimeter (W/cm² or mW/cm²). In UV curing, the term intensity is also commonly used to describe irradiance; however, irradiance more correctly describes the concept of UV arriving at a two-dimensional substrate.²

Radiant energy density is the energy arriving at a surface per unit area. A square centimeter is again the unit area and radiant energy density is expressed in units of joules or millijoules per square centimeter (J/cm² or mJ/cm²). The radiant energy density is the time integration of irradiance. In UV curing, the term dose is also commonly used to describe radiant energy density.²

It should be noted that there is a maximum irradiance output from a UV system at a given power level that is concentrated at a specified location underneath the UV emitter. While irradiance attenuates as distance away from the specified location increases, most applications orient the UV source and setup so that the curing surface is always in the spot of maximum irradiance. As a result, irradiance is treated as a fixed value, while radiant energy density is variable and can be increased by slowing the line speed, increasing the number of UV systems directed at the curing area or by passing the UV source over the curing surface multiple times. This fact applies to mercury arc, microwave and LED systems alike.

With traditional UV systems, we tend to communicate in nominal terms of Watts/cm or Watts/inch. While this terminology loosely applies to electrode and microwave UV systems, it doesn't apply to LED systems at all. On the other hand, both irradiance (W/cm^2) and energy density (J/cm^2) at the curing surface for a given

wavelength are important whether the emitter is mercury arc, microwave or LED. While the values themselves do not necessarily need to be measured, the curing system and setup must yield the UV requirements of the ink or coating chemistry in order to obtain full cure.

The irradiance value of 2, 4, 8 or 10 W/cm^2 for a given LED system (and commonly quoted by LED equipment manufacturers) is typically measured at the emitting window of the LED array. It attenuates significantly as the distance between the emitting window and the curing surface increases. It should be noted that the focal point commonly referenced with conventional UV systems is not typically applicable for LED systems. While LED chips can be packaged in an arrangement so that all UV energy is directed to a specified focal point, this is not common practice. Current UV-LED systems more closely resemble the flood profile of traditional systems.

The number of LED chips in the actual array, the way the chips are powered and arranged, the line speed

and the number of passes under the LED will affect the total energy density at the curing surface. As a result, it is important to first select or arrange the UV-LED array(s) to cover the desired curing surface in one direction. The corresponding number of LED chips or the length of the LED array(s) in the perpendicular direction is then determined by the application's energy density requirements. This is a variable factor based on chemistry and line speed.

Both applications with faster line speeds and chemistry that requires greater energy density will result in the need for LED arrays with more LED chips, the use of multiple LED arrays or arrays that have been optimized for greater output, or the use of repeated passes underneath the LED array(s) as demonstrated by scanning head wide-format UV printers. All of this currently complicates the process of selecting an LED system for a given application. In other words, several different LED systems all rated at 8 W/cm^2 will all produce 8 W/cm^2 at the emitting window; however, this rating

FIGURE 8

Table-top integrating sphere and floor-standing integrating sphere



does nothing to communicate the overall dimensions of the curing area; the number of LED chips; the packing density or optimization of the diodes; or the resulting energy density (J/cm^2) for your specific setup and line speed. The best advice is to work closely with your ink and coating manufacturer as well as your UV-LED and dispensing supplier; and, if at all possible, conduct trials to determine whether UV-LEDs are currently a fit for your application.

There are a wide range of UV radiometers on the market designed to measure UV generated by traditional broadband mercury arc and microwave UV systems. There have been many articles written on these meters as well as their proper use, limitations and design variations. As a result, I won't cover this material other than to make it very clear that none of the existing broadband meters can be used to measure the output from UV-LEDs. I cannot emphasize this enough.

UV radiometers designed for use with broad band mercury arc and microwave UV systems will not correctly measure the UV output generated by UV-LEDs.

There are only a few companies in the world currently manufacturing UV-LED chips or dies. Each manufacturer measures the UV output of the LEDs in an integrating sphere, also known as an Ulbricht sphere. This device is best described as a hollow sphere with a highly reflective coating on the interior surface that allows for uniform scattering of light. Photos of typical integrating spheres are shown in Figure 8. *Light rays incident on any point on the inner surface are, by multiple scattering reflections, distributed equally to all other such points and effects of the original direction of such light are minimized.*³

Chip manufacturers place a single LED die or arrangement of dies inside

FIGURE 9

Power output representation for a 405 nm LED source

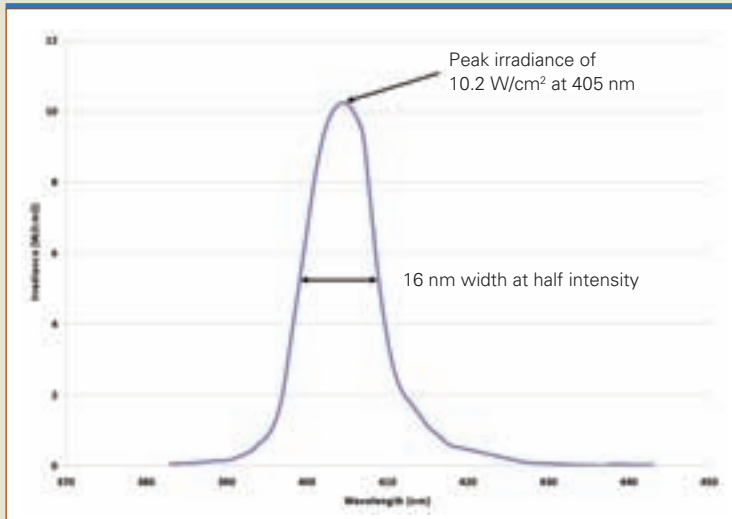

the integrating sphere and close the door. The die is powered and the UV energy is released from the LED over its entire viewing angle. The emitted UV bounces around inside the sphere and the energy that is radiated onto a detector of known area and located somewhere on the

sphere's inside surface is measured. Measurements are taken in 1 nm bands and a mathematical computation that includes the sphere's circumference and the LED size is used to determine the total UV output in W/cm^2 . For most current and potential users of UV-LEDs, it's not necessary to understand all the

FIGURE 10

Typical radiometer sensitivity (UVA response curve)

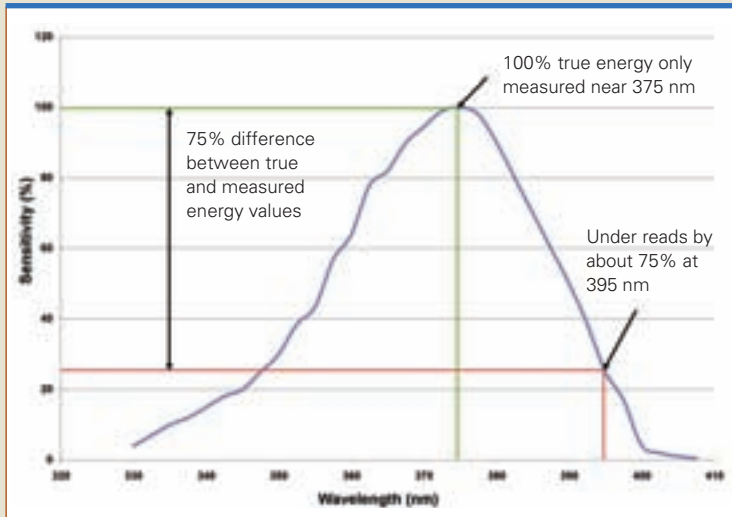

physics behind an integrating sphere or how the irradiance is exactly calculated. What you should take away, however, is an appreciation of the complexities involved in accurately measuring UV-LED irradiance and how integrating spheres, due to their shape and size, aren't practical measuring tools for most commercial UV-LED applications.

LED chip manufacturers specify LEDs based on the tolerance of the peak wavelength. The tolerance is not something that is engineered into the manufacturing process, but rather something that is measured after production. The peak wavelength of a finished chip is determined using an integrating sphere and the chip is categorized or binned with other LEDs that have a peak wavelength that falls within the same tolerance range. The tighter the bin width (i.e., the smaller the tolerance), the more expensive the dies become. Typical wavelength tolerances are +/- 5 nm, +/- 10 nm and +/- 15 nm. In general, the greater the diode's irradiance and the tighter the binning, the more expensive the chip.

While looser bin selection results in cheaper dies, the process cannot be guaranteed. In other words, a wider bin selection does not mean a wider width of wavelengths. It just means less control over the wavelength. A randomly selected range of dies between 380 nm and 420 nm could all be 380 nm, 420 nm or some mixed variation between the limits. In practice, however, most chips within a given bin range tend to be skewed toward the upper limits.

A narrow bell-shaped curve, as shown in Figure 9, provides a generic representation of the UV distribution from an LED source centered at 405 nm. In this case, the LED has a peak value of 10.2 W/cm² at 405 nm at the chip surface. At 8 nm on either side of the peak (397 nm and 413 nm), the intensity falls to 2.0 W/cm². While this particular LED may provide sufficient

FIGURE 11

Typical radiometer sensitivity (UVV response curve)

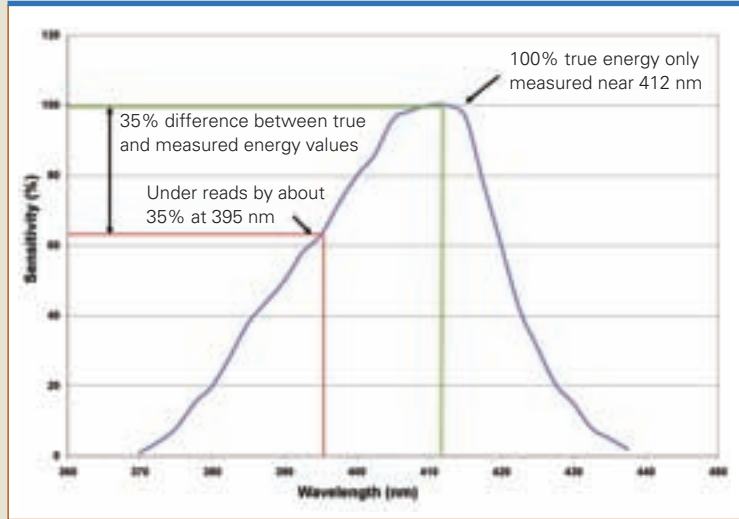
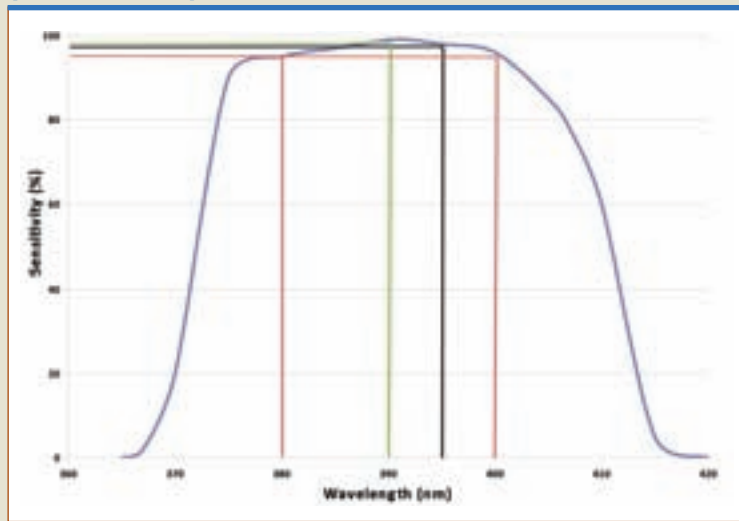

FIGURE 12

Radiometer sensitivity required for UV-LEDs (380-400 nm)



UV to cure a given ink or coating, it is difficult to quantify the amount of UV that actually reaches the curing surface. This is because integrating spheres are not a practical tool to use in a production environment, and most radiometers are not tuned to the specific wavelengths emitted by UV-LEDs.

In the lab and in the field, many UV-LED trials have produced desired curing results; however, the results have often been downplayed since the radiometer readings produced irradiance and energy density values significantly lower than those recorded with mercury arc and microwave curing

systems. Measuring UV output is an extremely important tool in maintaining and comparing UV processes; however, if incorrect and inappropriate tools are used, it's simply a meaningless exercise.

Commonly used devices for measuring UV irradiance and energy density are fitted with four distinct sensors, each designed to measure one of the four UV bandwidths (UUV, UVA, UVB and UVC). The individual sensors have a response curve that was engineered to fit conventional broadband UV-curing systems and were never intended to capture output concentrated in the 380-400 nm range. The graphs in Figures 10 and 11 represent the sensitivity response curves of typical UVA and UVV sensors. The UVA sensor is centered at 375 nm and under reads the peak UV irradiance of a 395 nm LED system by 75%. Conversely, the UVV sensor is centered slightly above 410 nm and under reads the peak output of a 395 nm LED system by approximately 35%.

Only radiometers with flat response curves, as illustrated in Figure 12, are capable of producing accurate UV irradiance (W/cm^2) and energy density (J/cm^2) readings from UV-LED systems in the 380-400 nm bandwidth range. A single channel radiometer specifically fitted to this measurement profile and contained in the well-known hockey puck style transporter was introduced to the market in early 2010. Only by using meters of this specific design can accurate measurements of UV output from a UV-LED curing system be obtained. Please keep in mind, however, that all instruments have some inherent measuring error and you should contact the manufacturer or read the manual to adequately understand the device's limitations. For example, radiometers are typically accurate to +/-10% from the calibrated value and repeatable to +/-5%. In addition, temperature variations of 0.2% / °C can also affect readings.

Comparing LED Technologies

As you begin or continue to conduct your own evaluation of LED technology, there are several questions that you should consider.

- What is the peak wavelength and bin tolerance of the LED array, and what is the impact on the ink or coating chemistry?
- What is the irradiance specification of the LED array?
- Where and how was the irradiance specification measured?
- What are the requirements of the curing application in terms of irradiance and energy density?
- Does the broadband ink or coating chemistry cure with UV-LEDs or does it need to be reformulated to match the narrow band UV-LED wavelengths?
- Can similar LED performance results be achieved at the same operational line speed or throughput used with conventional UV systems?
- What are the criteria for the physical installation of the LED array (moving or static head, single or multiple pass, area to be cured, existence and types of space restrictions)?
- What is gained or lost in using LEDs (power consumption, heat, efficiency, operating cost, purchase price)?

It is important to note that there are no dumb questions when it comes to UV-LEDs. It is equally important to note that suppliers don't yet have all the answers. If you ask a question and don't get an answer or the answer doesn't make sense, please keep asking. We are all still learning and sometimes the answers aren't yet known. In other cases, the

answers may change quickly with rapid advancements in the technology. Please don't let this discourage you. If it turns you off to the technology, you may quickly find yourself left behind. As I mentioned at the beginning of the article and will now reiterate, while UV-LEDs are still not the right fit for many applications, the momentum of technological advancement and implementation continues to increase at an astonishing and exciting rate, thus making more and more applications more plausible! ■

References

1. Held, Gilbert. *Introduction to Light Emitting Diode Technology and Applications*. Florida: Auerbach Publications. 2009.
2. Raymont, Jim. "Establishing and Maintaining a UV Process Window" *RadTech Report*. May/June 2002: 14-25.
3. *Integrating Sphere*. Wikipedia. January 7, 2010. March 15, 2010. http://en.wikipedia.org/wiki/Integrating_sphere

—Jennifer Heathcote is general manager, North America, for Integration Technology in Chicago, Ill.